



JMB322 RAID Port Multiplier Chip

Overview

JM micron JMB322 is a single chip, 1 to 2-ports Serial ATA II Port Multiplier with RAID function support. It is designed to provide SATA port expansion, data protection and performance aggregation at various applications.

JMB322 uses JM micron's production-proven Multi-port Serial ATA PHY technology and JM micron-proprietary storage processor to provide very high efficient SATA RAID operation. With an easy configuration scheme, the device can be a pure port multiplier which provides SATA port expansion just like a SATA Hub, or hard-drive performance booster which provides a high performance device seen by host controller or hard-drive data protector which automatically backup data to prevent data loss from hard-drive damage.

JMB322 is a self-contained storage processor chip which completely frees up the main CPU loading and the SATA ports comply with eSATA specification, making it suitable for use in both internal system and external storage applications

Compliance

- Compliant with *Serial ATA II Port Multiplier Spec. Revision 1.1*
- Compliant with *Serial ATA II PHY Electrical Spec. Revision 1.0*
- Compliant with *Serial ATA High Speed Serialized AT Attachment Spec. Revision 2.5*

General

- Integrated 3-port SATA II PHY
- Integrated PLL for SATA II interface
- Total three independent SATA channel
- Integrated uP, PROM and SRAM for firmware programming
- Integrated high performance RAID storage processor
- Fabricated in 0.13um CMOS Standard Logic Process
- 1.3V core and 3.3V I/O power supply
- Available in 48-pin QFN package

SATA

- Supports 3-port 3.0Gbps SATA II interface
- Supports SATA II Gen2i and Gen2m (External SATA Connection, eSATA)
- Output swing control and automatic impedance calibration for SATA II PHY
- Supports asynchronous signal recovery



- Supports spread spectrum clocking
- Supports partial / slumber power saving mode
- Automatically speed negotiation for 3 Gbps or 1.5 Gbps
- Supports BIST and loopback mode
- Supports staggered spin-up
- Supports 48-bit LBA addressing
- Supports ATAPI drives
- Supports Native Command Queue (NCQ)
- Supports Hot-Plug
- Supports Asynchronous Notification
- Supports PM aware and non-PM aware host

RAID

- Fully hardware-accelerated RAID Engine
- No driver, BIOS or software required for RAID operation
- No external DRAM or processor required for RAID operation
- Independent of device SATA port connection sequence
- Supports RAID levels: 0 / 1 / JBOD
- SATA In-band application interface
- Supports more than 2Tera Bytes RAID drive
- Supports on-line command based bad sector recovery
- Supports on-line Auto-Rebuild
- Rebuild speed: 200GB/hour
- Rebuild proceed continuously between power cycling
- Supports Matrix-RAID
- Supports various RAID configuration and monitoring method

GPIO

- Supports 15 GPIOs
- Supports I2C interface
- Supports ISA interface
- Supports SPI interface
- Supports LED indicators

Functional Description

JMB322 is a highly integrated single chip. It integrates three high-speed Serial I/O's, three SATA upper layers, a high-performance RAID engine, a microprocessor, SRAM, PROM, a high efficient data bus and other control logic into the chip. With proper firmware programming, JMB322 can be used as SATA port multiplier or RAID system. The following paragraph describes each functional block in detail.

Block Diagram

Figure 3.1 Function View of JMB322

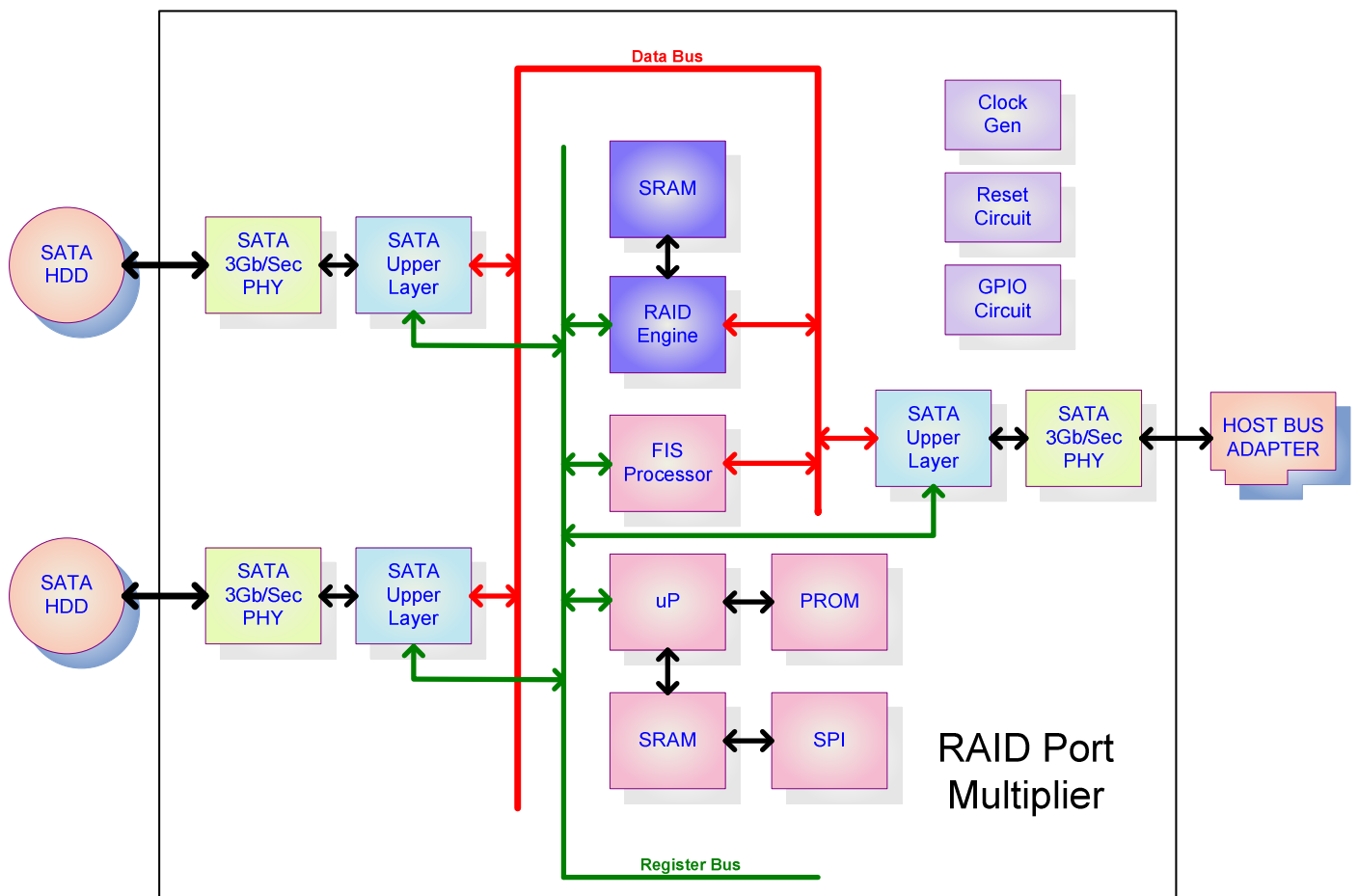

Supporting Document

1	Product Brief
2	Data Sheet
3	Hardware Design Guide
4	Application Schematic

Contact Information

Department	Email
Sales	sales@jmicron.com
Tech. Support	fae@jmicron.com